

optional limit switch: brake open / closed

optional limit switch: lining wear

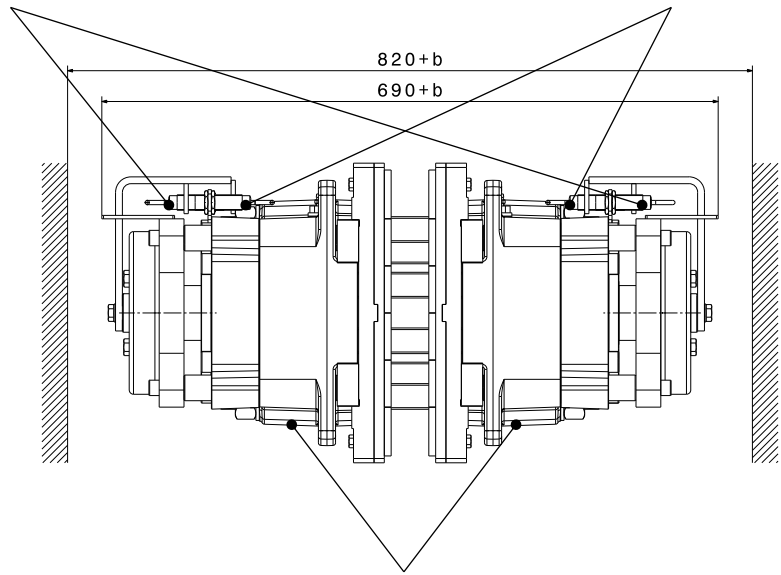

hydraulic connection G 1/2"

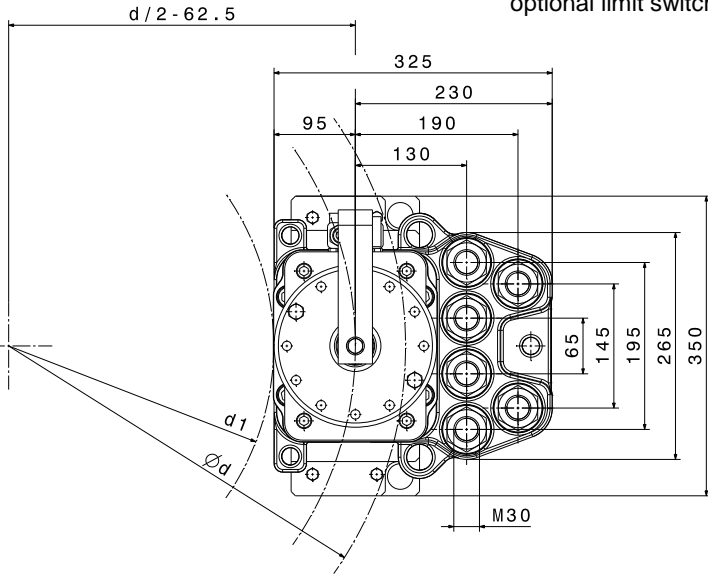
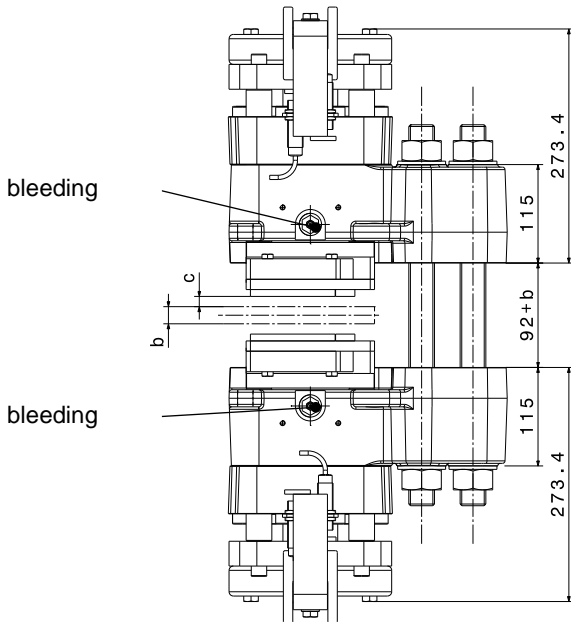

SHI-Type		161	162	
<b>Clamping Force <math>F_A</math></b>				
$F_A$	with airgap $c = 1$ mm	kN	108	190
$F_A$	with airgap $c = 2$ mm	kN	98	160
$F_A$	with airgap $c = 3$ mm	kN	88	128
<b>Torque Calculation</b>				
$M_{Br}$	braking torque	Nm	$2 \times F_A \times \mu \times (d/2-62,5)$	
<b>Hydraulic</b>				
$P_L$	release pressure	bar	90	170
$P_{max}$	max. pressure	bar	150	205
$V_{max}$	volumen at $c = 2,0$ mm	ltr	0,062	
<b>Brake Discs</b>				
$b$	disc thickness	mm	$\geq 20$	
$d$	disc- $\emptyset$	mm	$\geq 900$	
$d_1$	max. hub or drum- $\emptyset$	mm	$d-325$ mm	
<b>Dimensions</b>				
$L \times B \times H = 325 \times (690+b) \times 350$ mm				
weight: 230 kg				

Mounting Studs		
$n$	quantity	6
	size, grade	M30, 12.9
$M_A$	fastening torque	Nm 2200 at $\mu=0,14$
Linings		
	material	sinter
	friction coefficient*	0,4

\*average friction coefficient with standard material combination and a circumferential speed up to 15 m/s